



Sethco Division

Polypropylene / PVDF

Self Priming and End Suction Magnetic Drive, Seal-less Pumps

OPERATION MANUAL

**End Suction
Models:**

**PM-1035
KM-1035
PM-1040N
KM-1040N
PM-1040W
KM-1040W**



**Self Priming
Models:**

**PMSP-1035
KMSP-1035
PMSP-1040N
KMSP-1040N
PMSP-1040W
KMSP-1040W**





SAFETY RULES FOR SETHCO PUMPS

800 Emlen Way, Telford, PA 18969

Tel: 800-645-0500 • 215-799-2577 • Fax: 215-799-0920

Website: www.sethco.com • e-mail: sales@sethco.com

West Coast Office: 230 N. Crescent Way, Unit I, Anaheim, CA 928014 • Tel: 714-991-0270 • Fax: 714-991-8107

CONGRATULATIONS! *You have just purchased a Sethco Pump, a quality industrial product manufactured to exacting standards.*

To insure prolonged life of your purchase, please take a few minutes to review the operating instructions and become familiar with the pump.

Thank you for choosing a Sethco product. We look forward to serving your future requirements for quality industrial corrosion resistant pumps and filter supplies.

- 1. KEEP BYSTANDERS AWAY** - All unauthorized persons should be kept a safe distance from work area.
- 2. WEAR APPROPRIATE PROTECTIVE APPAREL.**
Such as gloves, aprons, footwear and faceshields, etc. when installing, operating or maintaining the unit.
- 3. KEEP HANDS AND FINGERS FROM IMPELLER.**
- 4. KEEP FACE AWAY** - Don't look into hose, pump discharge, or suction.
- 5. AUXILIARY EQUIPMENT** - Hoses must be suitable for the chemical to be transferred. They must also be selected to safely contain the pressure at the operating temperature. Clamps must not be attacked by any corrosive environment or splashing.
- 6. DO NOT USE FOR** - any other application unless written permission is obtained from the factory.
- 7. ALL CONNECTIONS** - should be checked for secure and leakproof fit.
- 8. NEVER** - Turn pump on unless valves are open.
9. When wiring motor, follow all electrical safety codes.
10. Always disconnect power source before performing work on or near the motor or its connected load. Lock it in the open position and tag it to prevent unexpected application of power. Failure to do so could be fatal.
11. Avoid touching exterior of motor. It may be hot enough to be painful or cause injury. With modern motors this condition is normal if operated at rated load and voltage - modern motors operate at higher temperatures.
12. Protect the power cable from sharp objects. Do not kink power cable and never allow the cable to come in contact with oil, grease, hot surfaces, or chemicals.
13. Do not handle the unit with wet hands or when standing in water as electrical shock could occur. Disconnect main power before handling unit for **ANY REASON!**
14. Isolate pump by closing suction and discharge valves prior to any maintenance. Attach lockouts to valves to prevent accidental opening.
15. No piping or foundation strains on pump are permitted. Any strain will cause misalignment and early failures.
- 16. INSTALLATION - OPERATION - MAINTENANCE** of this equipment must be performed by trained and qualified personnel. Unauthorized handling of this equipment can be hazardous.



800 Emlen Way, Telford, PA 18969

Tel: 800-645-0500 • 215-799-2577 • Fax: 215-799-0920

Website: www.sethco.com • e-mail: sales@sethco.com

West Coast Office: 230 N. Crescent Way, Unit I, Anaheim, CA 928014 • Tel: 714-991-0270 • Fax: 714-991-8107

TERMS AND CONDITIONS OF SALE

The terms and conditions stated below and on the face of any Met Pro Corp., Sethco Div. (referred to below as Sethco) quote or order form govern, and any order is accepted subject thereto. These terms and conditions supersede any terms and conditions on buyer's quote or order form or attachments thereto which are inconsistent with the provisions hereof.

Prices: All prices and specifications are subject to change without notice. Prices charged will be those in effect at time of shipment.

Orders: All orders are subject to acceptance by Sethco at its home office in Hauppauge, New York. All errors, clerical or otherwise, are subject to correction. When total net billing for material is less than the minimum charge in effect at the time of shipment, invoicing will be made at the minimum charge. Acceptance of all orders is subject to credit approval.

Taxes: Sethco's prices do not include sales, use or excise taxes. Consequently, in addition to the price quoted, the amount of any present or future taxes based on sale, use, manufacture or transportation shall either be paid by the buyer or the buyer shall provide Sethco with an acceptable exemption certificate. **Terms:** Terms of payment are net 30 days, F.O.B. Hauppauge, New York, unless otherwise stated on the face of any quote or order form.

Shipments: Scheduled shipping dates are approximate. Title to and risk of loss for the material shall pass to the buyer upon delivery thereof by Sethco to the carrier or delivery service.

Cancellation—All orders upon

acceptance by Sethco cannot be canceled without Sethco's written consent, and then only upon payment to Sethco of reasonable and proper cancellation charges.

Returns: No goods may be returned unless authorization in writing has been received from Sethco's home office. After authorization is received, all goods must be returned, freight prepaid, to our home office in Hauppauge, New York.

Warranty: Sethco warrants (unless otherwise written on the face of any quote or order form) that products of Sethco's manufacture are free of defects in material or workmanship. Any part, except as indicated below, proven to be defective within one year from date of shipment, after inspection by and to the satisfaction of Sethco, will be repaired or replaced free of charge, F.O.B. Hauppauge, New York, on return of such claimed defective part as outlined under "Returns" above. Excluded are Carboy and Drum pumps, which are warranted for 180 days. Also excluded are all used and/or reconditioned items and parts which carry no warranty, and all normal wearing parts such as, but not limited to, shafts, mechanical seals, bearing, gaskets, etc.

The liability of Sethco under this warranty, whether the claim is based on contract or negligence, shall in no case exceed the cost of repairing or replacing the part as herein provided, and upon expiration of the warranty period, all such liabilities shall terminate.

Sethco assumes no liability for equipment which has been tampered with or altered in any way, or for consequential loss or damage of

any kind, and the buyer, by acceptance of such equipment, assumes all liability for the consequences of its use or misuse by the buyer, his employees, or others.

UNLESS THE BUYER HAS FURNISHED SETHCO WITH COMPLETE INFORMATION REGARDING THE INTENDED APPLICATION AND SERVICE REQUIREMENTS OF THE ITEMS ORDERED, SETHCO GUARANTEES ONLY THE IDENTITY OF THE MATERIALS USED IN THE CONSTRUCTION OF THE EQUIPMENT SHIPPED.

Within the meaning of this warranty a defect in any part of the equipment shall not operate to condemn the entire unit when such part is capable of being renewed, repaired or replaced. Sethco assumes no field expense for service or parts on equipment without written authority from Sethco. Sethco does not warrant motors, gauges, electrical control equipment or other products not manufactured by Sethco, such being subject to warranties as may be given by their respective manufacturers.

The foregoing warranty is made in lieu of all other warranties, guarantees, obligations or liabilities, expressed or implied, by Sethco or its representatives. All statutory or implied warranties, other than of title, are hereby expressly negated and excluded. All illustrations and provisions in specifications are descriptive and are not intended as warranties.

Since the policy of Sethco is one of continual improvement, we reserve the right to change design or materials at any time, without giving notice or creating any obligation to

Now ORDER Sethco products ONLINE at www.sethco.com

PD-344-02C

END SUCTION MAGNETIC DRIVE SEALLESS PUMP

PARTS LIST OPERATION INSTRUCTIONS

July 1, 2001

Supersedes PD-344-02C dated 10/1/00



800 Emlen Way, Telford, PA 18969

Tel: 800-645-0500 • 215-799-2577 • Fax: 215-799-0920

Website: www.sethco.com • e-mail: sales@sethco.com

West Coast Office: 230 N. Crescent Way, Unit I, Anaheim, CA 928014 • Tel: 714-991-0270 • Fax: 714-991-8107

END SUCTION... MAGNETIC DRIVE... SEALLESS

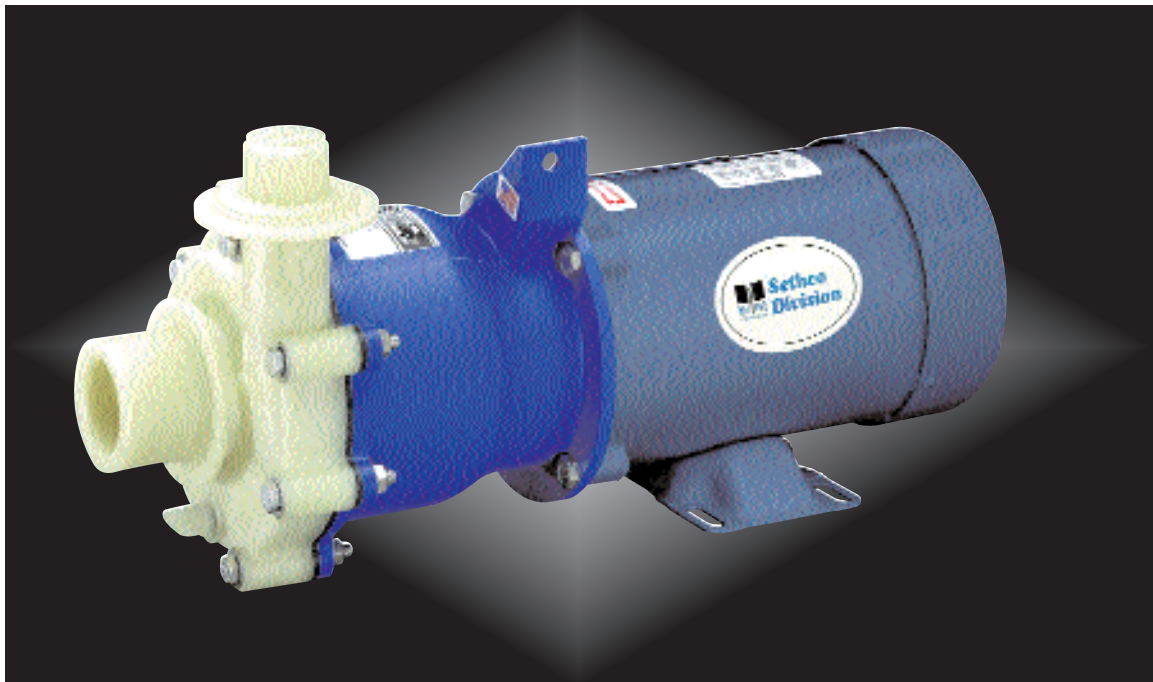

MODELS:

PM-1035NT • PM-1040NT • PM-1040WT
KM-1035NT • KM-1040NT • KM-1040WT

**PARTS LIST FOR
SETHCO END SUCTION,
MAGNETIC DRIVE,
SEALLESS PUMPS**

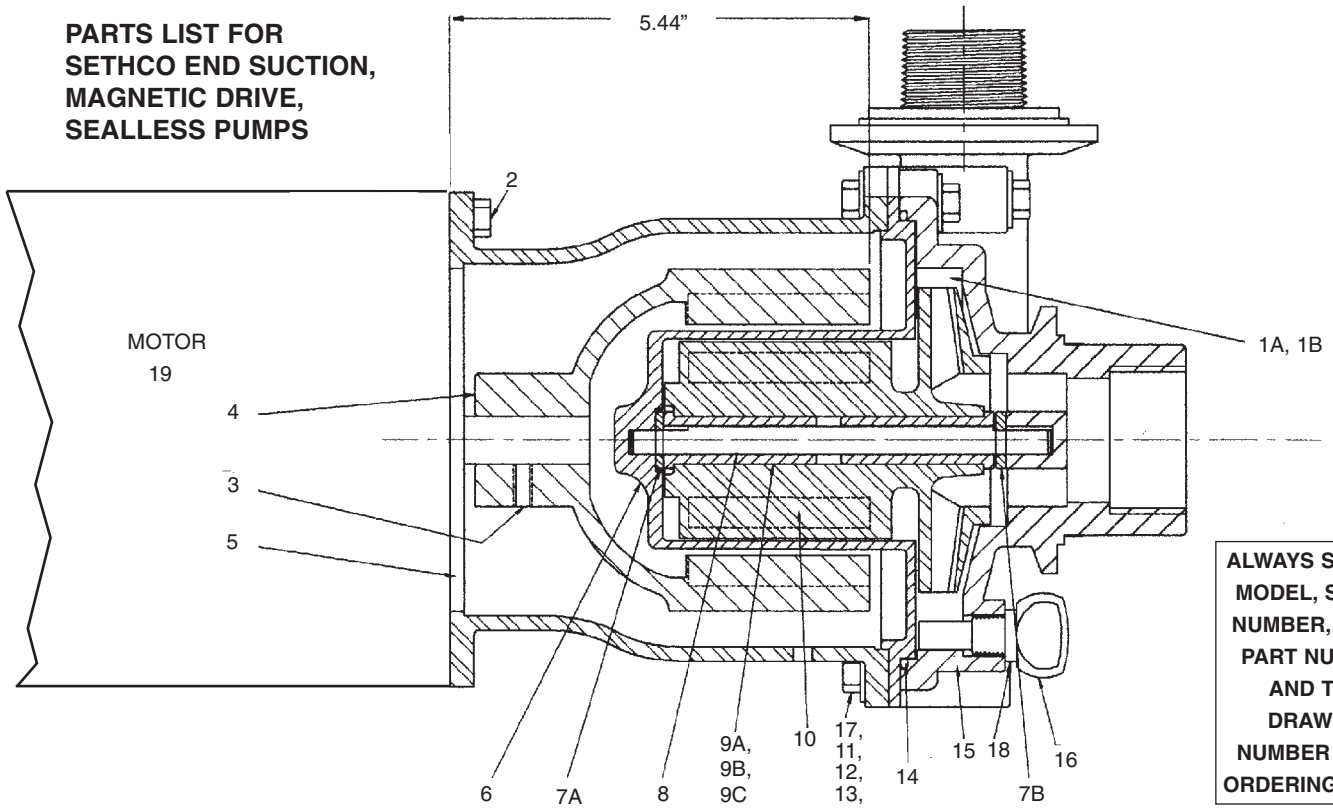

ITEM	DESCRIPTION	QUANTITY	PMSM MODEL (NOTE 1)		KMSM MODEL (NOTE 2)	
			MATERIAL	PART NUMBER	MATERIAL	PART NUMBER
1A	CUTWATER 4.ON/4.OW (small)	1	POLYPRO	183P201326-576	PVDF	183P201326-383
1B	CUTWATER 3.5N (large)	1	POLYPRO	183P201327-576	PVDF	183P201327-383
2	BOLT (to motor)	4	STAINLESS STEEL	790P03161-680	STAINLESS STEEL	790P03161-680
3	SETSCREW	2	STAINLESS STEEL	800P022004-720	STAINLESS STEEL	800P022004-720
4	DRIVE MAGNET	1	NYLON	561P201308-520	NYLON	561P201308-520
5	ADAPTER	1	NORYL	010P400169-513	NORYL	010P400169-513
6	CUP	1	PVDF	180P301061-383	PVDF	180P301061-383
7A	WASHER (REAR)	1	CERAMIC	990P101934-150	CERAMIC	990P101934-150
7B	WASHER (FRONT)	1	CERAMIC	990P102222-150	CERAMIC	990P102222-150
8	SHAFT	1	CERAMIC	850P101933-150	CERAMIC	850P101933-150
9A	BEARING (Note 3)	2	CARBON	080P102025-100	CARBON	080P102025-100
9B	BEARING (Note 3)	2	SILICONE/CARBIDE	080P1021221-755	SILICONE/CARBIDE	080P1021221-755
9C	BEARING (Note 3)	2	RYTON	080P101936-660	RYTON	080P101936-660
10	IMPELLER ASSEMBLY	1	SEE CHART ON NEXT PAGE			
11	HEX NUT	8	STAINLESS STEEL	610P51618-670	STAINLESS STEEL	610P51618-670
12	WASHER	16	STAINLESS STEEL	990P516-680	STAINLESS STEEL	990P516-680
13	BOLT (long)	4	STAINLESS STEEL	790P5168204-680	STAINLESS STEEL	790P5168204-680
14	O-RING	1	VITON	590P102512-830	VITON	590P102512-830
15	CASING	1	POLY-PRO	133P400167-576	PVDF	133P400167-383
16	DRAIN PLUG	1	POLY-PRO	660P102497-576	PVDF	660P102497-383
17	BOLT (short)	4	STAINLESS STEEL	790P5168104-680	STAINLESS STEEL	790P5168104-680
18	O-RING (Drain Plug)	1	VITON	590P2110-830	VITON	590P2110-830
19	MOTOR	1	—	SEE TABLE A	—	SEE TABLE A
33	SUPPORT DISK (NOTE 4)	1	STAINLESS STEEL	250P202086-685	STAINLESS STEEL	250P202086-685

TABLE A TEFC MOTORS*

ITEM	DESCRIPTION	ITEM	MATERIAL	115/208-230V, 50/60 Hz 1 Phase	MATERIAL	208-230/308-460V, 50/60 Hz. 3 Phase
19	MOTOR, 1/2HP	1	—	574P00M32313D40	—	574P00M35333D40
19A	MOTOR, 3/4HP	1	—	574P00N32313D40	—	574P00N35333D40
19B	MOTOR, 1HP	1	—	574P01032313D40	—	574P01035333D40

NOTE 1: Polypropylene is glass reinforced. **NOTE 2:** PVDF is carbon reinforced. **NOTE 3:** Impeller magnet assembly (10) includes 2 each of bearing (9)
NOTE 4: Not shown, located between cup and adapter

IMPELLER MAGNET ASSEMBLY BEARING MATERIAL

IMPELLER MATERIAL	DIAMETER	CARBON	RYTON	SILICONE CARBIDE
POLYPRO	3.5N	562P2014001-579	562P2014001-578	562P2014001-573
	4.0N	562P2014002-579	562P2014002-578	562P2014002-573
	4.0W	562P2014003-579	562P2014003-578	562P2014003-573
PVDF	3.5N	562P2014001-383	562P2014001-388	562P2014001-386
	4.0N	562P2014002-383	562P2014002-388	562P2014002-386
	4.0W	562P2014003-383	562P2014003-388	562P2014003-386

INSTALLATION

Allow sufficient head room and floor space for proper inspection and maintenance.

PIPING

All piping must be supported independently of the pump. The piping should always line up naturally with the pump. Never draw or force the piping to the suction or discharge of the pump. All installations should be properly designed for changes in ambient operating temperatures. Omission of this could result in severe strain transmitted to the pump. The piping should be as short and direct as possible. Avoid all unnecessary elbows, bends, and fittings, as they increase friction losses in the piping.

SUCTION PIPING

The length of the suction pipe should be as short as possible. **SUCTION PIPING MUST BE AIR TIGHT.**

DISCHARGE PIPING

A valve in the discharge line should be of a design to allow throttling or flow control. Centrifugal pumps should never be throttled on the suction side.

INITIAL START UP

On first start up, and any time motor is reconnected to an electrical outlet, check direction of motor rotation as follows:

1. Fill pump with liquid as directed in priming instructions below.
2. Turn switch "on" and then "off" immediately. Observe rotation. It should be in the direction of the arrow on motor or pump (counterclockwise when looking at pump end of motor).
3. To reverse rotation refer to instructions on motor.

PRIMING AND STARTING

1. **Flooded Suction** - Open all valves in suction and discharge lines. When pump is completely filled with liquid, turn motor on. Sometimes, especially when pumping higher specific gravity liquids, the pump cannot start pumping with an open discharge line. To overcome this, simply close the discharge valve after the pump is filled with liquid, then turn on motor. Wait several seconds for pressure to build up, then slowly open discharge valve to desired flow.

2. **Non-Flooded Suction** - Slowly fill the pump and suction line from the inlet side until the liquid flows from the pump discharge port and inlet hose is full. Make sure that no entrapped air remains. Close the discharge valve. Turn on motor. Wait several seconds for pressure to build up. Slowly open discharge valve to desired flow.

DISASSEMBLY

1. Before disassembly, the electric motor should be either disconnected from its power source, or the switch or circuit breaker must be secured in an "off" position so that the motor cannot be accidentally started.
2. Depending upon the fluid being pumped, the proper protective equipment should be worn (gloves, mask, respirator, goggles or safety glasses, etc.) to prevent contact with the fluid or vapors in the pump or pipelines.
3. Check the valves on the suction and discharge lines to be sure they are closed and secured.
4. The pump is provided with a drain, the liquid trapped in the pump and piping should be drained. Care should be taken to either trap the fluid in a container or to divert it to a proper disposal area so that the area around the pump and base will not be contaminated.
5. Remove bolts (13, 17), washer (12), and nut (11).
6. Remove casing (15).
7. Remove shaft (8)
8. Remove front thrust washer (7B).
9. Remove impeller bearings (9) from impeller assembly (10).
10. Remove rear thrust washer (7A).
11. Remove cup (6).
12. Remove bolt (2) and adapter (5).
13. Remove setscrews (3) and drive magnet (4).
14. If bearing (9) replacement is necessary, remove old bearings from impeller assembly (10). Use care not to damage impeller hube.
15. If cutwater (1) replacement is necessary, remove old cutwater from casing (15).

INSPECTION

1. Check all parts for cracks and chemical attack.
2. Check cup (6) for signs of rubbing on the OD and ID.
3. Check impeller (10) on OD for rubbing in cup ID.

- Check face of impeller for rubbing on casing (15).
- Place shaft (8) into casing (15). Assemble impeller (10) onto shaft. Check running clearance between impeller OD and cutwater. When new, clearance should be 0.020". If measured clearance is 0.080" or more, replace cutwater

ASSEMBLY (Completely dismantled pump)

- Assemble drive magnet (4) to motor (19). Open end of drive magnet must be 5.44" \pm 1/16" from machined motor face. Secure with setscrews (3) making sure that set screws do not enter the motor shaft key way.
- Mount adapter (5) to motor and secure with bolts (2). Locate adapter vent hole at the six o'clock position.
- Press one bearing (9) into front end of impeller assembly (10) first. Then press second bearing into opposite end and put aside.
- Insert cutwater (1) and drain plug (16) into casing (15).
- Install front ceramic washer (7B) with o-ring (18) on one end of shaft (8) with dull side facing shaft end. Insert shaft end with washer into center hole of casing.
- Slide impeller-magnet assembly, with bearings, onto shaft with impeller end facing casing.
- Install rear ceramic washer (7) with shiny side facing carbon bearing.
- Place o-ring (14) on cup (6) at step.
- Place cup with o-ring over impeller-magnet and shaft assembly. Then rotate cup gently until shaft flat engages "D" hole in inside bottom of cup.
- Further rotate cup and shaft until all bolt holes are aligned.
- Squeeze cup to casing gently to ensure that o-ring seats properly.
- Holding pump assembly firmly, insert into drive magnet attached to motor with pump discharge facing up.
- Install any two opposing casing bolts (13) or (17), washers (12) and nuts (11). and hand tighten to hold pump assembly in place.
- Now install remaining nuts, bolts, and washers tighten all eight nuts and bolts evenly and securely. Assembly is now complete. Refer to installation and starting procedures.

TROUBLESHOOTING

A. Pump will not prime or insufficient liquid delivered:

- Air leakage in suction piping
- Suction lift too high or insufficient suction pressure
- Impeller, casing, suction pipe or strainer plugged with solids
- Wrong rotation
- Magnetic couple slipping

B. Not enough pressure:

- Speed too low.
- Air or gases in the liquid.
- Check impeller diameter.
- Mechanical defects (impeller clearance too great: impeller damaged).
- Wrong rotation.
- Pressure gauge in the wrong place, (or defective gauge).

C. Pump takes too much power:

- Speed too high.
- Head lower than rating; pumping beyond design point.
- Liquid heavier than specified; check viscosity and specific gravity.
- Mechanical defects (rotating element rubbing).

D. Pump is noisy:

- Hydraulic noises—cavitation, insufficient suction pressure.
- Mechanical defects (rotating parts are binding, loose or broken).

E. Pump leaks:

- Teflon o-rings are subject to creep. When a leak is detected, stop the pump and check the clamps and fasteners to be sure they are secure. Should the leak continue, secure the pump and inspect all the components for cracks and wear, especially the cup.

SELF PRIMING MAGNETIC DRIVE SEALLESS PUMP



800 Emlen Way, Telford, PA 18969
Tel: 800-645-0500 • 215-799-2577 • Fax: 215-799-0920

Website: www.sethco.com • e-mail: sales@sethco.com

West Coast Office: 230 N. Crescent Way, Unit I, Anaheim, CA 928014 • Tel: 714-991-0270 • Fax: 714-991-8107

PARTS LIST OPERATION INSTRUCTIONS

June 1, 2001

Supersedes PD-344-01C, dated 12/1/92

SELF PRIMING...MAGNETIC DRIVE...SEALLESS



**Models: PMSP-1035NT • PMSP-1040NT • PMSP-1040WT
KMSP-1035NT • KMSP-1040NT • KMSP-1040WT**

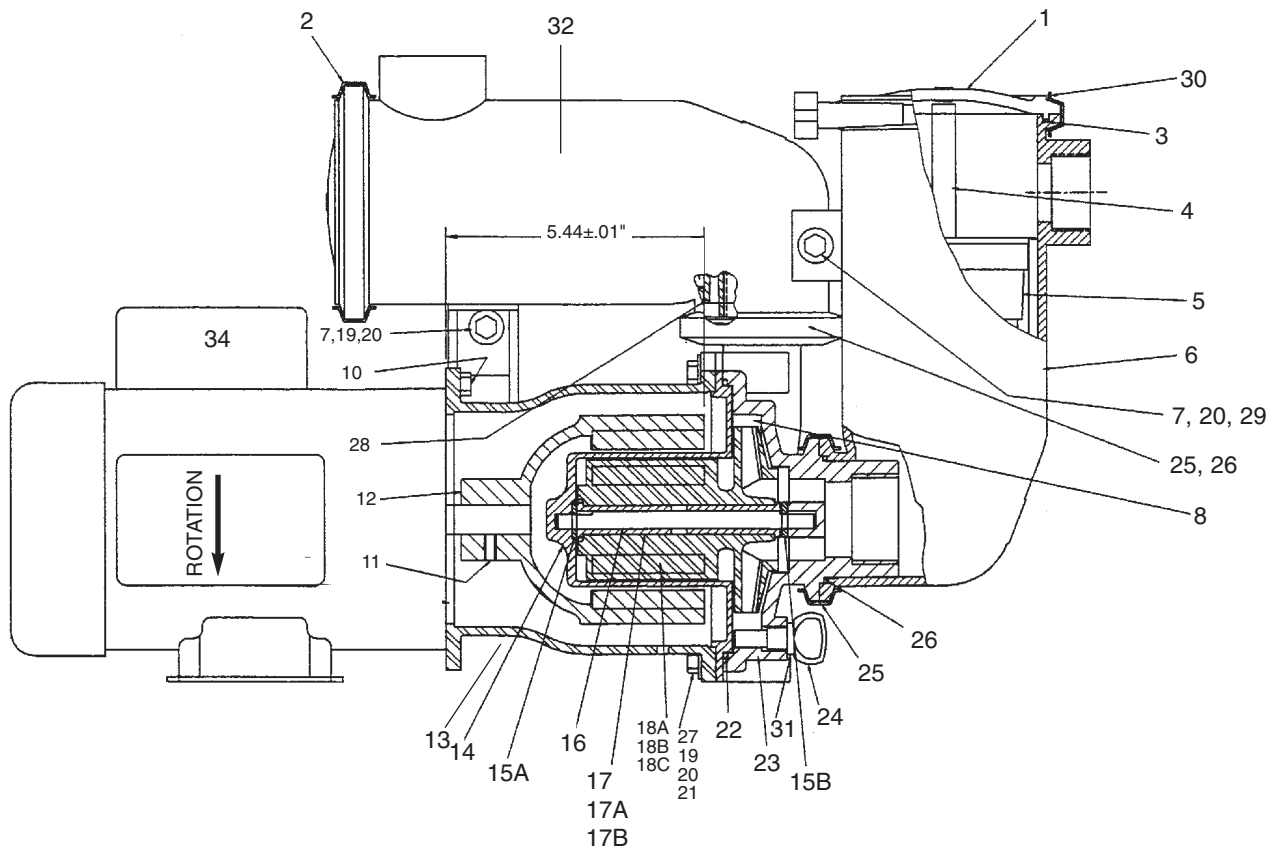

INSTALLATION

Allow sufficient head room and floor space for the addition of priming liquid and for proper inspection and maintenance.

PIPING

All piping must be supported independently of the pump. The piping should always line up naturally with the pump. Never draw or force the piping to the suction or discharge of the pump. All installations should be properly designed for changes in ambient operating temperatures. Omission of this could result in severe strain transmitted to the pump. The piping should be as short and direct as possible. Avoid all unnecessary elbows, bends, and fittings, as they increase friction losses in the piping.

SUCTION PIPING

The length of the suction pipe should be as short as possible to prevent excessively long priming time, as priming times are directly proportional to suction piping volumes.

SUCTION PIPING MUST BE AIR TIGHT OR PUMP WILL NOT PRIME. DO NOT INSTALL ANY TYPE OF CHECK VALVE IN THE SUCTION PIPE.

DISCHARGE PIPING

A valve in the discharge line should be of a design to allow throttling or flow control. Centrifugal pumps should never be throttled on the suction side. **THE DISCHARGE VALVE MUST BE OPEN AND THE DISCHARGE PIPING VENTED DURING THE PRIMING CYCLE TO ALLOW THE AIR EVACUATED FROM THE SUCTION PIPING TO ESCAPE.**

If a check valve is used in the discharge piping it must be equipped with an air bleed bypass or an air bleed return to the pumped liquid source. If you are not consult factory.

INITIAL START UP

On first start up, and any time motor is reconnected to an electrical outlet, check direction of motor rotation as follows:

1. Fill pump with liquid as directed in priming instructions below.
2. Turn switch "on" and then "off" immediately. Observe rotation. It should be in the direction of the arrow on motor or pump (counterclockwise when looking at pump end of motor).
3. To reverse rotation refer to instructions on motor.

PRIMING AND STARTING

Check to be sure suction and discharge valves are open. Also be sure discharge piping is vented and suction piping is submerged in the fluid to be pumped. Remove clamp (30) and cover (1). Fill primer chamber (6) to inlet with 2 quarts of priming fluid. Reinstall the cover (1) and secure the clamp (30).

Start the pump. Initially, air will be pumped from the suction piping. When all the air is evacuated, the unit will pump liquid.

DISASSEMBLY

1. Before disassembly, the electric motor should be either disconnected from its power source, or the switch or circuit breaker must be secured in an "off" position so that the motor cannot be accidentally started.
2. Depending upon the fluid being pumped, the proper protective equipment should be worn (gloves, mask, respirator, goggles or safety glasses, etc) to prevent contact with the fluid or vapors in the pump or pipelines
3. Check the valves on the suction and discharge lines to be sure they are closed and secured.

Continued on back page

SETHCO "PMSP/KMSP" SERIES MAGNETIC DRIVE, SEALLESS SELF PRIMING PUMPS

ITEM	DESCRIPTION	PMSP MODEL (NOTE 1)			KMSP MODEL (NOTE 2)	
		QUANTITY	MATERIAL	PART NUMBER	MATERIAL	PART NUMBER
1	COVER	2	POLYPRO	140P301062-576	PVDF	140P301062-383
2	CLAMP	1	STAINLESS STEEL	130P101994-680	STAINLESS STEEL	130P101994-680
3	O-RING	2	VITON	590P2244-830	VITON	590P2244-830
4	HANDLE	1	POLYPRO	391P201350-576	PVDF	391P201350-384
5	BASKET	1	POLYPRO	031P301075-576	PVDF	031P301075-384
6	PRIMER CHAMBER	1	POLYPRO	662P400168-576	PVDF	662P400168-383
7	HEX HEAD BOLT	2	STAINLESS STEEL	790P51619806-680	STAINLESS STEEL	790P51619806-680
8A	CUTWATER 4.ON/4.OW (small)	1	POLYPRO	183P201326-576	PVDF	183P201326-383
8B	CUTWATER 3.5N (large)	1	POLYPRO	183P201327-576	PVDF	183P201327-383
10	HEX HEAD BOLT	4	STAINLESS STEEL	790P03161-680	STAINLESS STEEL	790P03161-680
11	SETSCREW	2	STAINLESS STEEL	800P022004-720	STAINLESS STEEL	800P022004-720
12	MAGNETIC DRIVE	1	NYLON	561P201308-520	NYLON	561P201308-520
13	ADAPTER	1	NORYL	010P400169-513	NORYL	010P400169-513
14	CUP	1	PVDF	180P301061-383	PVDF	180P301061-383
15A	WASHER (REAR)	1	CERAMIC	990P101934-150	CERAMIC	990P101934-150
15B	WASHER (FRONT)	1	CERAMIC	990P102222-150	CERAMIC	990P102222-150
16	SHAFT	1	CERAMIC	850P101933-150	CERAMIC	850P101933-150
17	BEARING (Note 3)	2	CARBON	080P102025-100	CARBON	080P102025-100
17A	BEARING (Note 3)	2	SILICONE CARBON	080P1021221-755	SILICONE CARBON	080P1021221-755
17B	BEARING (Note 3)	2	RYTON	080P101936-660	RYTON	080P101936-660
18	IMPELLER ASSEMBLY	1	SEE BELOW			
19	HEX NUT 5/16"	9	STAINLESS STEEL	610P51618-670	STAINLESS STEEL	610P51618-670
20	WASHER 5/16"	20	STAINLESS STEEL	990P516-680	STAINLESS STEEL	990P516-680
21	HEX HEAD BOLT (LONG)	4	STAINLESS STEEL	790P5168204-680	STAINLESS STEEL	790P5168204-680
22	O-RING	1	VITON	590P102512-830	VITON	590P102512-830
23	CASING	1	POLY-PRO	133P400167-576	PVDF	133P400167-383
24	DRAIN PLUG	1	POLY-PRO	660P102497-576	PVDF	660P102497-383
25	CLAMP	2	STAINLESS STEEL	130P101993-680	STAINLESS STEEL	130P101993-680
26	O-RING	2	VITON	590P2230-830	VITON	590P2230-830
27	HEX HEAD BOLT (SHORT)	4	STAINLESS STEEL	790P5168104-680	STAINLESS STEEL	790P5168104-680
28	SPACER	1	POLY-PRO	770P102024-576	PVDF	770P102024-383
29	INSERT	1	BRASS	440P101995-080	BRASS	440P101995-080
30	CLAMP (WITH HAND KNOB)	1	STAINLESS STEEL	130P1019941-680	STAINLESS STEEL	130P1019941-680
31	O-RING	1	VITON	590P2110-830	VITON	590P2110-830
32	DISCHARGE CHAMBER ASSY (Note 4)	1	POLY-PRO	034P301068-576	PVDF	034P301068-383
33	SUPPORT DISK (NOTE 5)	1	STAINLESS STEEL	250P202086-685	STAINLESS STEEL	250P202086-685

TEFC MOTORS*

ITEM	DESCRIPTION	QUANTITY	115/208-230V, 50/60 Hz			208-230/308-460V, 50/60 Hz.	
			1 Phase			3 Phase	
34	MOTOR, 1/2HP	1	-	574P00M32313D40	-	574P00M35333D40	
34A	MOTOR, 3/4HP	1	-	574P00N32313D40	-	574P00N35333D40	
34B	MOTOR, 1HP	1	-	574P01032313D40	-	574P01035333D40	

* If your motor is "wired" at the factory, change the 1st 3 digits to 575. For other motors, consult factory

IMPELLER MAGNET ASSEMBLY BEARING MATERIAL

IMPELLER MATERIAL	DIAMETER	CARBON	RYTON	SILICONE CARBIDE
POLYPRO	3.5N	562P2014001-579	562P2014001-578	562P2014001-573
	4.0N	562P2014002-579	562P2014002-578	562P2014002-573
	4.0W	562P2014003-579	562P2014003-578	562P2014003-573
PVDF	3.5N	562P2014001-383	562P2014001-388	562P2014001-386
	4.0N	562P2014002-383	562P2014002-388	562P2014002-386
	4.0W	562P2014003-383	562P2014003-388	562P2014003-386

- NOTE 1:** Polypropylene is glass reinforced. **NOTE 2:** PVDF is carbon reinforced. **NOTE 3:** Impeller magnet assembly (18A, 18B, 18C) includes 2 each of bearing (17)
NOTE 4: Discharge chamber assembly (32) includes primer chamber (6), cover (1), clamp (2), o-ring (3) and insert (29).
NOTE 5: Not shown, located between cup and adapter.

4. The pump is provided with a drain, the liquid trapped in the pump and piping should be drained. Care should be taken to either trap the fluid in a container or to divert it to a proper disposal area so that the area around the pump and base will not be contaminated.
5. Remove bolts (7, 21, 27), washer (20) and nut (19).
6. Remove casing (23), primer (6) and discharge chamber (32) as a unit.
7. Remove shaft (16).
8. Remove front washer (15B).
9. Remove impeller assembly (18).
10. Remove rear washer (15A).
11. Remove cup (14).
12. Remove bolt (10) and adapter (13).
13. Remove setscrews (11) and drive magnet (12).
14. If bearing (17) replacement is necessary remove old bearings from impeller (18).
15. If cutwater (8) replacement is necessary remove old cutwater from casing (23).
16. Remove discharge chamber (32) assembly (32) if necessary.
17. Remove and disassemble priming chamber (6) only if necessary.
15. To install discharge chamber (32) place spacer (28) on casing discharge with slot facing up. Align spacer slot with divider in casing discharge.
16. Put o-ring (26) on casing discharge.
17. Install discharge chamber on casing discharge with the flat side of the support bracket touching the flat side of the adapter support bracket.
18. Install clamp (25) around the discharge flanges and tighten.
19. Put o-ring (26) on casing suction port and install priming chamber in vertical position.
20. Install clamp (25) and tighten.
21. Install bolt (7), washer (20), and nut (19) to connect discharge chamber (32) to motor adapter and tighten.
22. Install bolt (7) and washer (20) that connects priming chamber (6) to discharge chamber (32), and tighten.
23. Install priming basket handle (4) on basket (5) and place into priming chamber(6).
24. Install o-ring (3) on top of priming chamber (6), place cover (1) on priming chamber, install clamp (30) and tighten.

Assembly is now complete. Refer to installation and starting procedures

INSPECTION

1. Check all parts for cracks and chemical attack.
2. Check cup (14) for signs of rubbing on the OD and ID.
3. Check impeller (18) on OD for rubbing in cup ID. Check face of impeller for rubbing on casing (23).
4. Place shaft (16) into casing (23). Assemble impeller (18) onto shaft (16).
5. Check basket (5) for cracks and broken ribs.

ASSEMBLY (Completely dismantled pump)

1. Assemble drive magnet (12) to motor. Open end of drive magnet must be **5.44±.01"** from machined motor face. Secure with setscrews (11) making sure that set screws do not enter the motor shaft key way.
2. Mount adapter (13) to motor and secure with bolts (10). Locate adapter vent hole at the six o'clock position.
3. Press one bearing (17) into impeller end of impeller assembly (18) first. Then press the other bearing (17) into magnet end and put aside.
4. Insert cutwater (8) and drain plug (24) with o-ring (31) into casing (23).
5. Install front washer (15B) on one end of shaft (16) with dull side facing casing end. Insert shaft end with washer into center hole of casing (23).
6. Slide impeller assembly (18), with bearings (17), onto shaft with impeller (18) end facing casing (23).
7. Install rear washer (15A) with shiny side facing bearing.
8. Place o-ring (22) on cup (14) at step.
9. Place cup with o-ring over impeller assembly (18) and shaft (16). Then rotate cup (14) gently until shaft flat engages "D" hole in inside bottom of cup (14).
10. Further rotate cup (14) and shaft until all bolt holes are aligned.
11. Squeeze cup (14) to casing (23) gently to ensure that o-ring seats properly.
12. Holding pump assembly firmly insert into drive magnet attached to motor with pump discharge facing up.
13. Install any two opposing bolts (21) or (27) washers (20) and nuts (19), and hand tighten to hold pump assembly in place.
14. Now install remaining nuts, bolts, and washers. Tighten all eight nuts and bolts evenly and securely.

TROUBLESHOOTING

A. Pump will not prime or insufficient liquid delivered:

1. Air leakage in suction piping.
2. Discharge line closed.
3. Primer chamber (6) not sufficiently filled with priming fluid.
4. Suction lift too high or insufficient suction pressure.
5. Excessive internal clearances.
6. Impeller, casing, suction pipe or strainer plugged with solids.
7. Wrong rotation.
8. Wrong size volute cutwater (8) or cutwater missing.
9. Magnetic couple slipping.

B. Not enough pressure:

1. Speed too low.
2. Air or gases in the liquid.
3. Check impeller diameter.
4. Mechanical defects (impeller clearance too great: impeller damaged).
5. Wrong rotation.
6. Pressure gauge in the wrong place, (or defective gauge).

C. Pump takes too much power:

1. Speed too high.
2. Head lower than rating; pumping beyond design point.
3. Liquid heavier than specified; check viscosity and specific gravity.
4. Mechanical defects (rotating element rubbing).

D. Pump is noisy:

1. Hydraulic noises—cavitation, insufficient suction.
2. Mechanical defects (rotating parts are binding, loose or broken).

E. Pump leaks:

1. Teflon o-rings are subject to creep. When a leak is detected, stop the pump and check the clamps and fasteners to be sure they are secure. Should the leak continue, secure the pump and inspect all the components for cracks and wear.

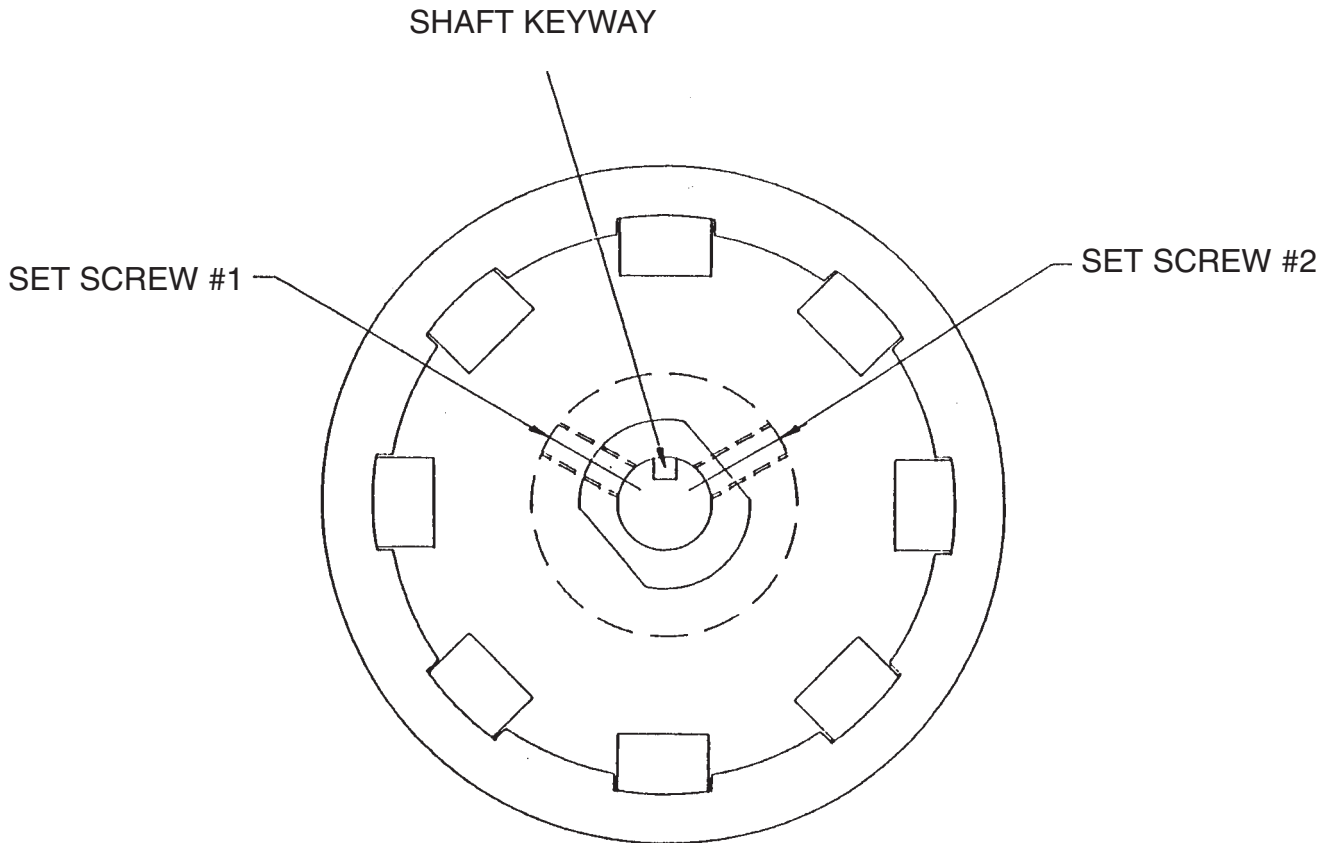

DRIVE BELL REPLACEMENT PROCEDURE

1. Slide drive bell onto motor shaft with keyway centered between both drive bell set screws, as shown.
2. Space drive bell face 5.44" from pump face. (See Sethco assembly drawing for details).
3. Tighten set screw #1. Then tighten set screw #2