



Sethco Division

Polypropylene / PVDF

Self Priming and End Suction Magnetic Drive, Seal-less Pumps

OPERATION MANUAL

**Self Priming
Models:**

PMSP-510

PMSP-525

PMSP-550

KMSP-510

KMSP-525

KMSP-550



**End Suction
Models:**

PM-510

PM-525

PM-550

KM-510

KM-525

KM-550





Sethco Division

800 Emlen Way, Telford, PA 18969

Tel: 800-645-0500 • 215-799-2577 • Fax: 215-799-0920

Website: www.sethco.com • e-mail: sales@sethco.com

West Coast Office: 230 N. Crescent Way, Unit I, Anaheim, CA 928014 • Tel: 714-991-0270 • Fax: 714-991-8107

SAFETY RULES FOR SETHCO PUMPS

CONGRATULATIONS! You have just purchased a Sethco Pump, a quality industrial product manufactured to exacting standards.

To insure prolonged life of your purchase, please take a few minutes to review the operating instructions and become familiar with the pump.

Thank you for choosing a Sethco product. We look forward to serving your future requirements for quality industrial corrosion resistant pumps and filter supplies.

1. **KEEP BYSTANDERS AWAY** - All unauthorized persons should be kept a safe distance from work area.
2. **WEAR APPROPRIATE PROTECTIVE APPAREL.**
Such as gloves, aprons, footwear and faceshields, etc. when installing, operating or maintaining the unit.
3. **KEEP HANDS AND FINGERS FROM IMPELLER.**
4. **KEEP FACE AWAY** - Don't look into hose, pump discharge, or suction.
5. **AUXILIARY EQUIPMENT** - Hoses must be suitable for the chemical to be transferred. They must also be selected to safely contain the pressure at the operating temperature. Clamps must not be attacked by any corrosive environment or splashing.
6. **DO NOT USE FOR** - any other application unless written permission is obtained from the factory.
7. **ALL CONNECTIONS** - should be checked for secure and leakproof fit.
8. **NEVER** - Turn pump on unless valves are open.
9. When wiring motor, follow all electrical safety codes.
10. Always disconnect power source before performing work on or near the motor or its connected load. Lock it in the open position and tag it to prevent unexpected application of power. Failure to do so could be fatal.
11. Avoid touching exterior of motor. It may be hot enough to be painful or cause injury. With modern motors this condition is normal if operated at rated load and voltage - modern motors operate at higher temperatures.
12. Protect the power cable from sharp objects. Do not kink power cable and never allow the cable to come in contact with oil, grease, hot surfaces, or chemicals.
13. Do not handle the unit with wet hands or when standing in water as electrical shock could occur. Disconnect main power before handling unit for **ANY REASON!**
14. Isolate pump by closing suction and discharge valves prior to any maintenance. Attach lockouts to valves to prevent accidental opening.
15. No piping or foundation strains on pump are permitted. Any strain will cause misalignment and early failures.
16. **INSTALLATION - OPERATION - MAINTENANCE** of this equipment must be performed by trained and qualified personnel. Unauthorized handling of this equipment can be hazardous.



Sethco Division

800 Emlen Way, Telford, PA 18969

Tel: 800-645-0500 • 215-799-2577 • Fax: 215-799-0920

Website: www.sethco.com • e-mail: sales@sethco.com

West Coast Office: 230 N. Crescent Way, Unit 1, Anaheim, CA 928014 • Tel: 714-991-0270 • Fax: 714-991-8107

TERMS AND CONDITIONS OF SALE

The terms and conditions stated below and on the face of any Met Pro Corp., Sethco Div. (referred to below as Sethco) quote or order form govern, and any order is accepted subject thereto. These terms and conditions supersede any terms and conditions on buyer's quote or order form or attachments thereto which are inconsistent with the provisions hereof.

Prices: All prices and specifications are subject to change without notice. Prices charged will be those in effect at time of shipment.

Orders: All orders are subject to acceptance by Sethco at its home office in Hauppauge, New York. All errors, clerical or otherwise, are subject to correction. When total net billing for material is less than the minimum charge in effect at the time of shipment, invoicing will be made at the minimum charge. Acceptance of all orders is subject to credit approval.

Taxes: Sethco's prices do not include sales, use or excise taxes. Consequently, in addition to the price quoted, the amount of any present or future taxes based on sale, use, manufacture or transportation shall either be paid by the buyer or the buyer shall provide Sethco with an acceptable exemption certificate. **Terms:** Terms of payment are net 30 days, F.O.B. Hauppauge, New York, unless otherwise stated on the face of any quote or order form.

Shipments: Scheduled shipping dates are approximate. Title to and risk of loss for the material shall pass to the buyer upon delivery thereof by Sethco to the carrier or delivery service.

Cancellation—All orders upon

acceptance by Sethco cannot be canceled without Sethco's written consent, and then only upon payment to Sethco of reasonable and proper cancellation charges.

Returns: No goods may be returned unless authorization in writing has been received from Sethco's home office. After authorization is received, all goods must be returned, freight prepaid, to our home office in Hauppauge, New York.

Warranty: Sethco warrants (unless otherwise written on the face of any quote or order form) that products of Sethco's manufacture are free of defects in material or workmanship. Any part, except as indicated below, proven to be defective within one year from date of shipment, after inspection by and to the satisfaction of Sethco, will be repaired or replaced free of charge, F.O.B. Hauppauge, New York, on return of such claimed defective part as outlined under "Returns" above. Excluded are Carboy and Drum pumps, which are warranted for 180 days. Also excluded are all used and/or reconditioned items and parts which carry no warranty, and all normal wearing parts such as, but not limited to, shafts, mechanical seals, bearing, gaskets, etc.

The liability of Sethco under this warranty, whether the claim is based on contract or negligence, shall in no case exceed the cost of repairing or replacing the part as herein provided, and upon expiration of the warranty period, all such liabilities shall terminate.

Sethco assumes no liability for equipment which has been tampered with or altered in any way, or for consequential loss or damage of

any kind, and the buyer, by acceptance of such equipment, assumes all liability for the consequences of its use or misuse by the buyer, his employees, or others.

UNLESS THE BUYER HAS FURNISHED SETHCO WITH COMPLETE INFORMATION REGARDING THE INTENDED APPLICATION AND SERVICE REQUIREMENTS OF THE ITEMS ORDERED, SETHCO GUARANTEES ONLY THE IDENTITY OF THE MATERIALS USED IN THE CONSTRUCTION OF THE EQUIPMENT SHIPPED.

Within the meaning of this warranty a defect in any part of the equipment shall not operate to condemn the entire unit when such part is capable of being renewed, repaired or replaced. Sethco assumes no field expense for service or parts on equipment without written authority from Sethco. Sethco does not warrant motors, gauges, electrical control equipment or other products not manufactured by Sethco, such being subject to warranties as may be given by their respective manufacturers.

The foregoing warranty is made in lieu of all other warranties, guarantees, obligations or liabilities, expressed or implied, by Sethco or its representatives. All statutory or implied warranties, other than of title, are hereby expressly negated and excluded. All illustrations and provisions in specifications are descriptive and are not intended as warranties.

Since the policy of Sethco is one of continual improvement, we reserve the right to change design or materials at any time, without giving notice or creating any obligation to

Now ORDER Sethco products ONLINE at www.sethco.com

PD-342-02

SELF PRIMING MAGNETIC-DRIVE SEAL-LESS PUMP

PARTS LIST
OPERATION INSTRUCTIONS

March 1, 2002



Sethco Division

800 Emlen Way, Telford, PA 18969

Tel: 800-645-0500 • 215-799-2577 • Fax: 215-799-0920

Website: www.sethco.com • e-mail: sales@sethco.com

West Coast Office: 230 N. Crescent Way, Unit I, Anaheim, CA 928014 • Tel: 714-991-0270 • Fax: 714-991-8107

SELF PRIMING...MAGNETIC-DRIVE...SEAL-LESS

500 SERIES



Models: PMSP-510 PMSP-525 PMSP-550
KMSP-510 KMSP-525 KMSP-550

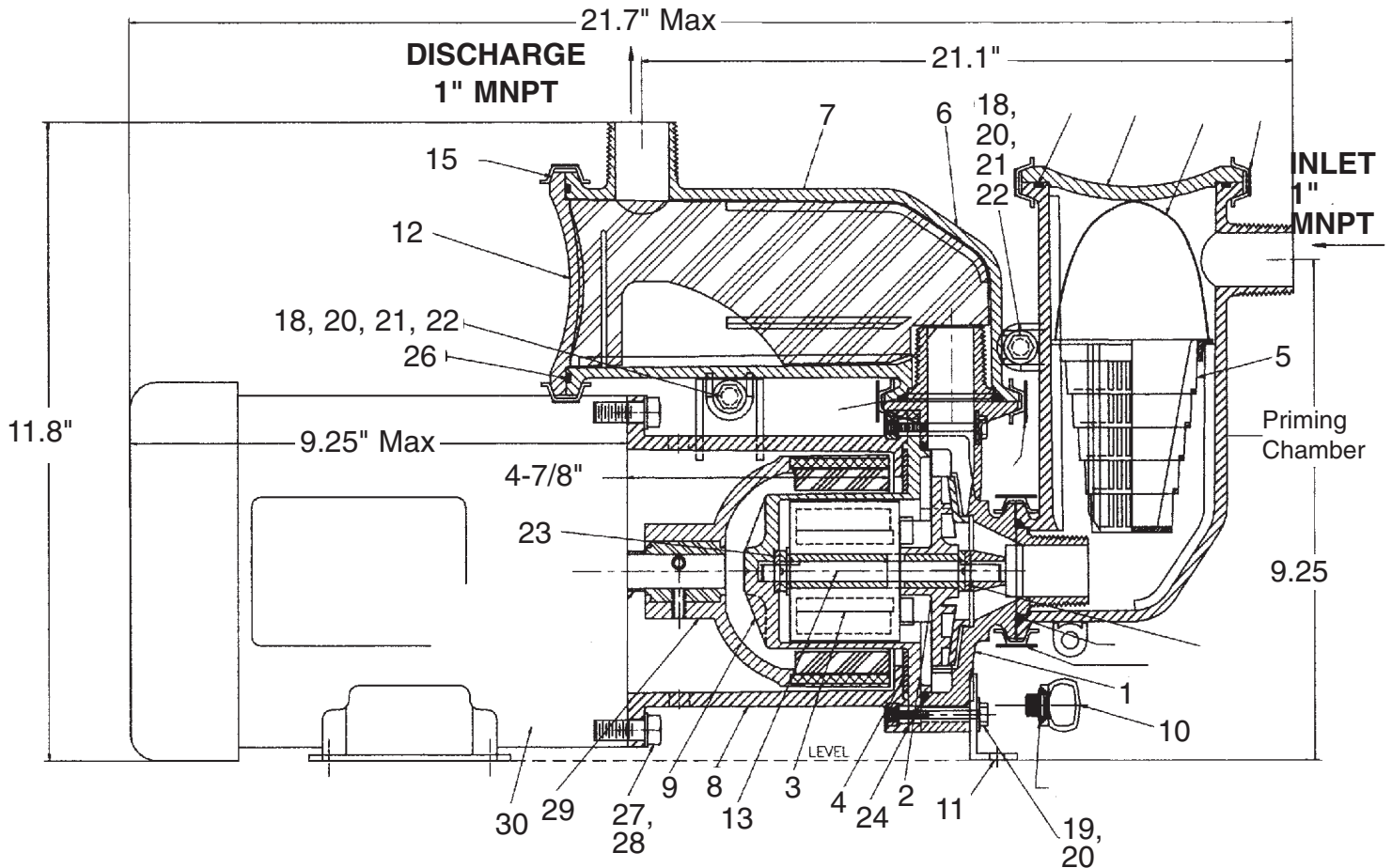

OPERATING INSTRUCTIONS

INSTALLATION

Allow sufficient head room and floor space for the addition of priming liquid and for proper inspection and maintenance.

PIPING

All piping must be supported independently of the pump. The piping should always line up naturally with the pump. Never draw or force the piping to the suction or discharge of the pump. All installations should be properly designed for changes in ambient operating temperatures. Omission of this could result in severe strain transmitted to the pump. The piping should be as short and direct as possible. Avoid all unnecessary elbows, bends, and fittings, as they increase friction losses in the piping.

SUCTION PIPING

The length of the suction pipe should be as short as possible to prevent excessively long priming time, as priming times are directly proportional to suction piping volumes. **SUCTION PIPING MUST BE AIR TIGHT OR PUMP WILL NOT PRIME. DO NOT INSTALL ANY TYPE OF CHECK VALVE IN THE SUCTION PIPE.**

DISCHARGE PIPING

A valve in the discharge line should be of a design to allow throttling or flow control. Centrifugal pumps should never be throttled on the suction side. **THE DISCHARGE VALVE MUST BE OPEN AND THE DISCHARGE PIPING VENTED DURING THE PRIMING CYCLE TO ALLOW THE AIR EVACUATED FROM THE SUCTION PIPING TO ESCAPE.**

If a check valve is used in the discharge piping it must be equipped with an air bleed bypass or an air bleed return to the pumped liquid source. If you are not consult factory.

INITIAL START UP

On first start up, and any time motor is reconnected to an electrical outlet, check direction of motor rotation as follows:

1. Fill pump with liquid as directed in priming instructions below.
2. Turn switch "on" and then "off" immediately. Observe rotation. It should be in the direction of the arrow on motor or pump (counterclockwise when looking at pump end of motor).
3. To reverse rotation refer to instructions on motor.

PRIMING AND STARTING

Check to be sure suction and discharge valves are open. Also be sure discharge piping is vented and suction piping is submerged in the fluid to be pumped. Remove clamp (15) and cover (12). Fill primer chamber (6) to inlet with 2 quarts of priming fluid. Reinstall the cover (12) and secure the clamp (15). Start the pump. Initially, air will be pumped from the suction piping. When all the air is evacuated, the unit will pump liquid.

You will need the following tools to disassemble and assemble the pump:

1. 5/16" nut driver or flat blade screw driver
2. 7/16" socket
3. 9/16" socket
4. 1/2" socket
5. Ratchet
6. 7/16" open-end wrench
7. 1/8" hex allen wrench
8. Torque wrench

DISASSEMBLY

1. Disconnect hoses, fittings and electrical power to the motor.
2. Drain the pump's inlet and discharge chambers by either using the supplied drain plug (10) or by tilting the assembly and draining out of the inlet port.
3. Using 1/2" socket and 7/16" wrench, loosen hardware holding the two priming chambers together and discharge chamber adapter. This is referred to as hardware 18, 20, 21, 22 on the parts drawing.
4. Using 5/16" nut driver, loosen 2 clamps that hold the priming chambers to the casing (1). Remove chamber assemblies (6) and (7) and o-rings (17). Inspect o-rings (17) and replace if necessary.
5. Using 7/16" socket, remove 6 screws and washers (19, 20). Bracket assembly (11) will also be removed at this point. Lift off casing (1), making sure shaft (13) stays with unassembled pump assembly.

Continued on back page

PARTS LIST

SETHCO "PMSP/KMSP - 500 SERIES" MAGNETIC-DRIVE, SEAL-LESS SELF PRIMING

PMSP MODELS

KMSP MODELS

ITEM	DESCRIPTION	QUANTITY	MATERIAL	PART NUMBER	MATERIAL	PART NUMBER
1	CASING	1	POLYPRO ¹	133P400368-576	KYNAR ¹	133P400368-383
2	IMPELLER	1	SEE TABLE BELOW			
3	DRIVEN MAGNET	1	SEE TABLE BELOW			
4	DISK	1	STAINLESS STEEL	250P202089-685	STAINLESS STEEL	250P202089-685
5	BASKET	1	POLYPRO	031P301435-580	KYNAR	031P301435-384
6	PRIMING CHAMBER	1	POLYPRO	662P400369-580	KYNAR	662P400369-384
7 ²	DISCHARGE CHAMBER ASSY	1	POLYPRO	034P4003691-576	POLYPRO	034P4003691-383
8	ADAPTER	1	NORYL	010P400367-513	NORYL	010P400367-513
9	CUP	1	POLYPRO	180P400373-576	KYNAR	180P400373-383
10	DRAIN PLUG	1	POLYPRO	660P2020831-576	KYNAR	660P2020831-383
11	BRACKET	1	NORYL	050P202091-513	NORYL	050P202091-513
12	COVER	2	POLYPRO	140P301432-576	KYNAR	140P301432-383
13	SHAFT	1	CERAMIC	850P102528-150	CERAMIC	850P102528-150
14	O-RING (STANDARD)	1	VITON	590P2111-830	VITON	590P2111-830
14A	O-RING	1	EDPM	590P2111-216	EDPM	590P2111-216
14B	O-RING	1	TEFLON	590P2111-770	TEFLON	590P2111-770
15	CLAMP	2	STAINLESS STEEL	130P102534-680	STAINLESS STEEL	130P102534-680
16	CLAMP	2	STAINLESS STEEL	130P102533-680	STAINLESS STEEL	130P102533-680
17	O-RING (STANDARD)	1	VITON	590P2223-830	VITON	590P2223-830
17A	O-RING	2	EPDM	590P2223-216	EPDM	590P2223-216
17B	O-RING	1	TEFLON	590P2223-770	TEFLON	590P2223-770
18	BOLT	1	STAINLESS STEEL	790P0220204-680	STAINLESS STEEL	790P0220204-680
19	BOLT	6	STAINLESS STEEL	790P022106-680	STAINLESS STEEL	790P022106-680
20	WASHER	10	STAINLESS STEEL	990P0205-680	STAINLESS STEEL	990P0205-680
21	HEX NUT	2	STAINLESS STEEL	610P0220-680	STAINLESS STEEL	610P0220-680
22	SCREW	1	STAINLESS STEEL	790P022006-680	STAINLESS STEEL	790P022006-680
23	THRUST WASHER	2	CERAMIC	990P101934-150	CERAMIC	990P101934-150
24	O-RING (STANDARD)	1	VITON	590P2246-830	VITON	590P2246-830
24A	O-RING	1	EPDM	590P2246-216	EPDM	590P2246-216
24B	O-RING	1	TEFLON	590P2246-770	TEFLON	590P2246-770
25	HANDLE	1	POLYPRO	391P201350580	KYNAR	391P201350384
26	O-RING (STANDARD)	1	VITON	590P2237-830	VITON	590P2237-830
26A	O-RING	2	EPDM	590P2237-216	EPDM	590P2237-216
26B	O-RING	1	TEFLON	590P2237-770	TEFLON	590P2237-770
27	WASHER	4	STAINLESS STEEL	990P3968706-680	STAINLESS STEEL	990P3968706-680
28	BOLT	4	STAINLESS STEEL	790P03161-680	STAINLESS STEEL	790P03161-680
29	DRIVE MAGNET ASSEMBLY	1	—	561P202085-520	—	561P202085-520

ITEM	TEFC MOTORS*	QUANTITY	115/208-230V, 50/60 Hz	208-230/308-460V, 50/60 Hz
30A	MOTOR, 1/ 4HP	1	574P00K12113D4E	—
30B	MOTOR, 1/ 3HP	1	574P00L12113D4E	—
30C	MOTOR, 1/ 2HP	1	574P00M32313D40	574P00M35333D40
30D	MOTOR, 3/ 4HP	1	574P00N32313D40	574P00N35333D40
30E	MOTOR, 1HP	1	574P01032313D40	574P01035333D40

* If your motor is "wired" at the factory, change the 1st 3 digits to 575 for low voltage or 576 for high voltage. For other motors, consult factory.

NOTE 1: Polypropylene is glass reinforced, Kynar is carbon reinforced.

NOTE 2: Discharge chamber assembly includes primer chamber (6), cover (12), clamp (15) and o-ring (26).

IMPELLER MAGNET ASSEMBLY BEARING MATERIAL

IMPELLER MATERIAL	MODEL	CARBON	RYTON	SILICONE CARBIDE
POLYPRO	510	430P301450-579	430P301450-578	430P301450-573
	525	430P301451-579	430P301451-578	430P301451-573
	550	430P301452-579	430P301452-578	430P301452-573
KYNAR	510	430P301450-381	430P301450-388	430P301450-386
	525	430P301451-381	430P301451-388	430P301451-386
	550	430P301452-381	430P301452-388	430P301452-386
DRIVEN MAGNET	POLY	562P301431-579	562P301431-578	562P301431-573
	KYNAR	562P301431-381	562P301431-388	562P301431-386

ASSEMBLY / DISASSEMBLY INSTRUCTIONS

6. Remove ceramic washer (23) and impeller (2). Inspect both for damage or wear.
7. Remove casing o-ring (24) from cup pilot. Inspect and replace if necessary.
8. Next remove cup assembly (9) with shaft (13), magnet (3), and rear washer (23) in it.
9. Remove parts from cup (9) and inspect.
10. Remove stainless support ring (4) from adapter face.
11. Using 9/16" socket, remove 4 bolts and washers (27, 28) from motor and adapter (8, 30). Remove adapter (8) from motor (30).
12. Use 1/8" hex allen wrench to loosen 2 set screws in drive magnet (29). Remove drive magnet (29) from motor (30).
13. Inspect all ceramic washers, bearings, and shaft for wear, chips or other signs of wear.
14. Remove drain plug (10) from casing (1) and inspect small o-ring (14). Replace if necessary.
15. Using 5/16" nut driver, remove clamps (15) on priming chamber covers (12). Remove covers and o-rings (26). Inspect o-rings and replace if necessary. Remove basket (5) and handle (25) from inlet chamber. Remove baffle (7) from discharge chamber.

Assembly:

1. Stand motor on fan end so that the shaft faces upward and the motor foot faces you.
2. Install drive magnet (29) onto motor shaft (30). Set distance from end of drive magnet to c-face of motor at 4-7/8" (+nothing) See figure 1.
3. Tighten 2 set screws using 1/8" hex allen wrench once proper distance has been determined.
4. Set adapter (8) onto motor c-face (30), piloting the adapter onto the motor pilot. The 4 holes in the adapter should line up with the motor holes when the small adapter "ear" is in the 1 o'clock position looking into the drive magnet (29). See figure 2.
5. Install 4 bolts and washers (27,28) using 9/16" socket. Torque bolts to 7-9 ft./lbs. max.
6. Check that drive magnet (29) spins freely without hitting adapter (8), turning drive assembly by hand.
7. Install rear ceramic washer (23) onto shaft 'D' (13) with reflective polished face towards longer section of shaft.
8. Insert shaft and washer into cup (9) piloting shaft (13) into cup and seating washer (23) into counter bore in cup (9). See figure 3.
9. Install driven magnet (3) onto cup/shaft subassembly with thrust bearing towards ceramic washer in cup. When installed, 4 standing lugs should be visible from open end of cup. Shaft should extend upward from cup. See figure 4.
10. Install impeller/bearing assembly (2) onto shaft so that 4 standing lugs on impeller locate into 4 slots on driven magnet (3). Turning impeller by hand should now turn driven magnet if properly seated. See figure 5. Place disk (4) onto adapter (8).
11. Lower cup/magnet/impeller assembly into adapter **using caution not to catch fingers between cup and adapter**. Make sure disk (4) is between cup and adapter and seated in cup (6) pilot. See figure 6.
12. Locate so that cup pilot seats into adapter pilot and all 6 hole sets line up.
13. Install front thrust washer (23) onto shaft (13) with reflective polished surface downward against impeller (2).
14. With motor base (30) at the 6 o'clock position, turn the ceramic shaft (13) so that the flat is at the 9 o'clock position. See figure 7.
15. Install o-ring (24) onto cup (9) pilot. O-ring should be flat on cup. See figure 7.
16. Install drain plug (10) and o-ring (14) into casing (1) until hand tight.
17. Lower casing (1) onto pump assembly, making sure that the flat in the shaft corresponds with the flat in the casing. Look through casing inlet to ensure proper location.
18. Casing (1) should pilot on o-ring (24) in cup (9). A small gap should be visible from side of assembly (approximately 1/16"). See figure 8.
19. Hand thread all 6 bolts with washers (19, 20) into casing. The bottom 2 should be through bracket (11) also. See figure 8.
20. Tighten 6 bolts using 7/16" socket until all bolts (19) are slightly compressing o-ring. Turn pump horizontal on flat surface, loosen 2 bracket bolts (19), and adjust bracket so that the bottom is flush

- with base surface. Re-tighten the 2 bolts now. See figure 9.
21. Torque all 6 bolts to 4 - 5 ft./lbs.
22. Install strainer basket (5) and handle (25) into inlet priming chamber (6). Make sure the basket (5) is below the inlet port. See figure 10.
23. Locate o-ring (26) into groove in chamber (6). Put cover (12) over o-ring, piloting into priming chamber. Dome of cover should be inside chamber. (See illustration) See figure 11.
24. Using 5/16" nut driver, tighten clamp (15) to hold cover to chamber. Make sure cover (12) stays piloted in chamber during tightening. Tighten clamps using 5/16" nut driver. Torque to 5 ft./lbs.
25. If baffle is detached from priming chamber, install baffle (7) into priming chamber (6). Make sure baffle seats between two grooves all the way down into the chamber. See figure 11. Repeat steps 23 and 24 for the installation for the o-ring, cover, and clamp to the discharge chamber. See figure 12.
26. Install 2 o-rings (17) over inlet and discharge thread shoulders. O-ring should seat flat against flange face. See figure 13.
27. Install discharge chamber assembly (6) with baffle and cover onto discharge port of casing. Use clamp (16) to tighten chamber to casing. Make sure that the tab on the priming chamber rests flat against bracket on adapter before tightening clamp. Tighten clamp using 5/16" nut driver, torque to 5 ft./lbs. Do not fully tighten yet.
28. Install bolt (18), 2 washers (20), and nut (22) to secure chamber (6) to adapter (8) Use 1/2" socket and 7/16" wrench to tighten. Torque to 6 ft./lbs. See figure 14.
29. Install inlet chamber assembly (6) with strainer basket and cover onto inlet port of casing. Use clamp (16) to tighten chamber to casing. Make sure that the tab on the inlet chamber corresponds with the long circular boss on the discharge chamber. Tighten clamp (16) using 5/16" nut driver. Do not fully tighten yet.
30. Install bolt (13), 2 washers (20) and hex nut (21) through long circular boss in discharge chamber and through flat tab in inlet chamber tighten using 1/2" socket and 7/16" wrench. Torque to 6 ft./lbs. See figure 15.
31. Now tighten 2 clamps (16) to 5 ft/lbs each. Assembly is now complete. See figure 16.

You are now ready to fill the priming chambers and wire the motor properly.

TROUBLESHOOTING

A. Pump will not prime or insufficient liquid delivered:

1. Air leakage in suction piping
2. Suction lift too high or insufficient suction pressure
3. Impeller, casing, suction pipe or strainer plugged with solids
4. Wrong rotation
5. Magnetic couple slipping

B. Not enough pressure:

1. Speed too low.
2. Air or gases in the liquid.
3. Check impeller condition.
4. Mechanical defects (impeller clearance too great: impeller damaged).
5. Wrong rotation.
6. Pressure gauge in the wrong place, (or defective gauge).

C. Pump takes too much power:

1. Speed too high.
2. Head lower than rating; pumping beyond design point.
3. Liquid heavier than specified; check viscosity and specific gravity.
4. Mechanical defects (rotating element rubbing).

D. Pump is noisy:

1. Hydraulic noises—cavitation, insufficient suction pressure.
2. Mechanical defects (rotating parts are binding, loose or broken).

E. Pump leaks:

1. When a leak is detected, stop the pump and check the clamps and fasteners to be sure they are secure. Should the leak continue, secure the pump and inspect all the components for cracks and wear, especially the cup.

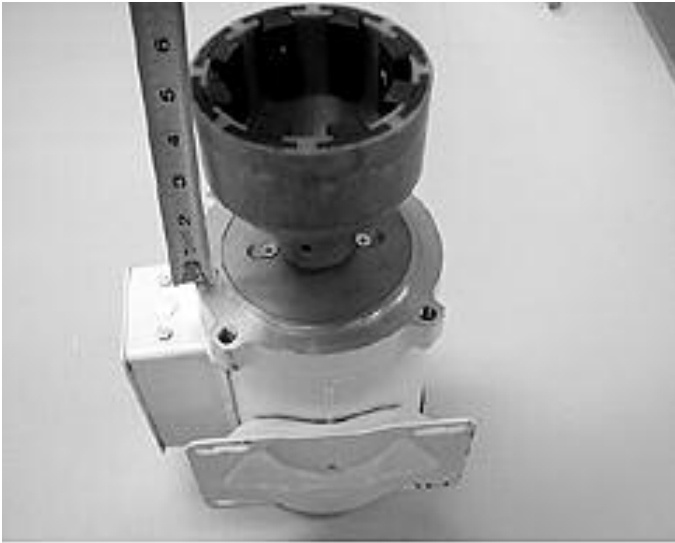

FIGURE 1

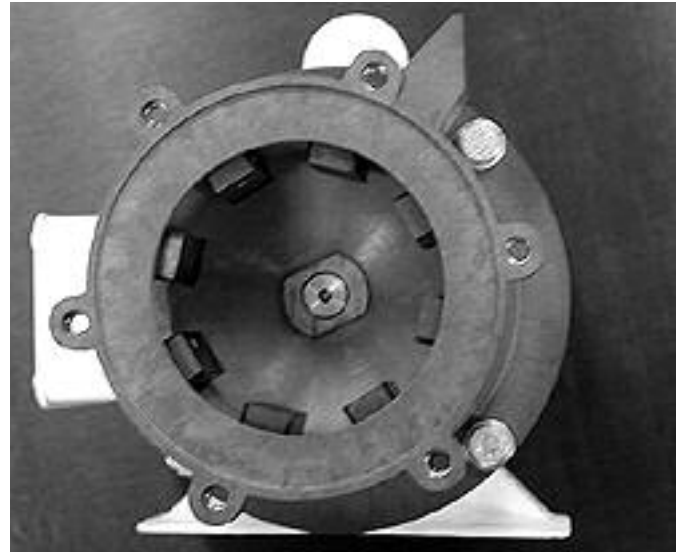

FIGURE 2



FIGURE 3

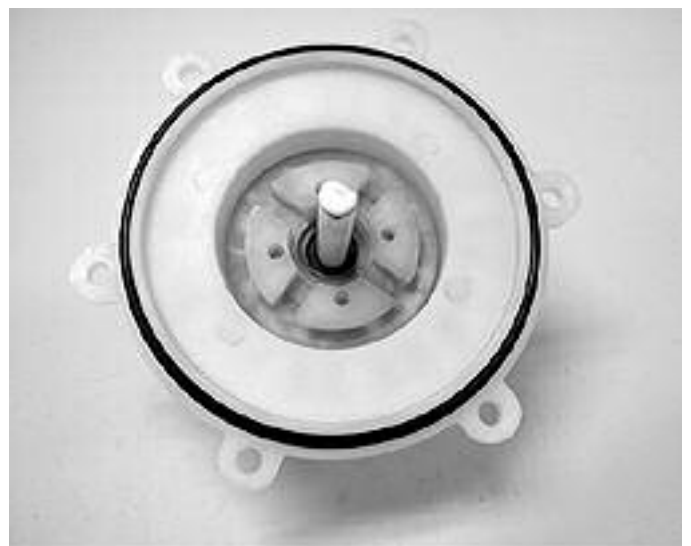

FIGURE 4



FIGURE 5



FIGURE 6

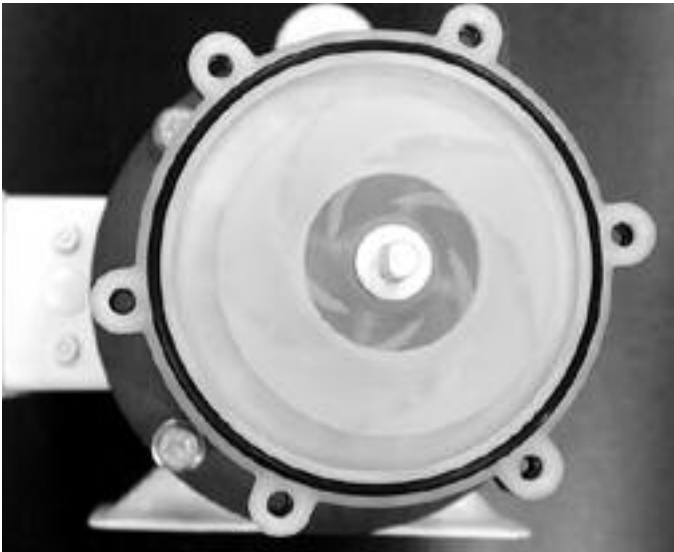

FIGURE 7

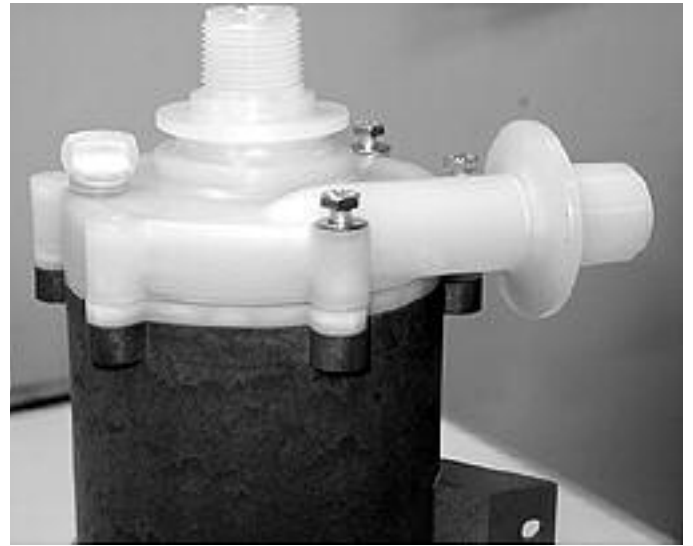

FIGURE 8



FIGURE 9

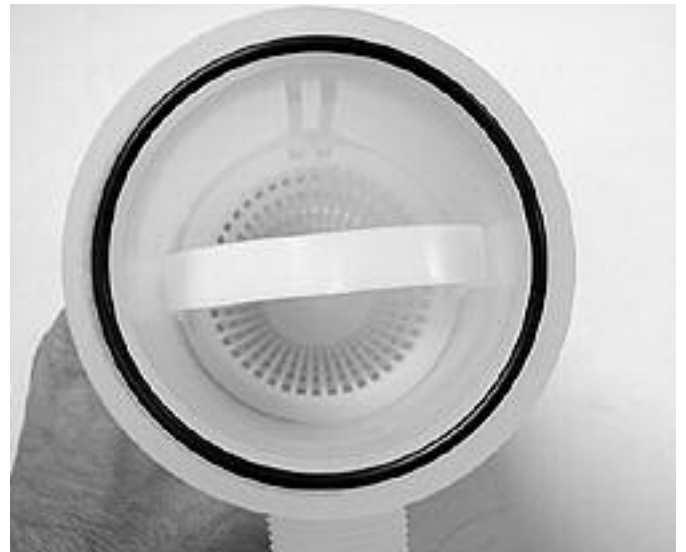

FIGURE 10



FIGURE 11



FIGURE 12



FIGURE 13



FIGURE 14

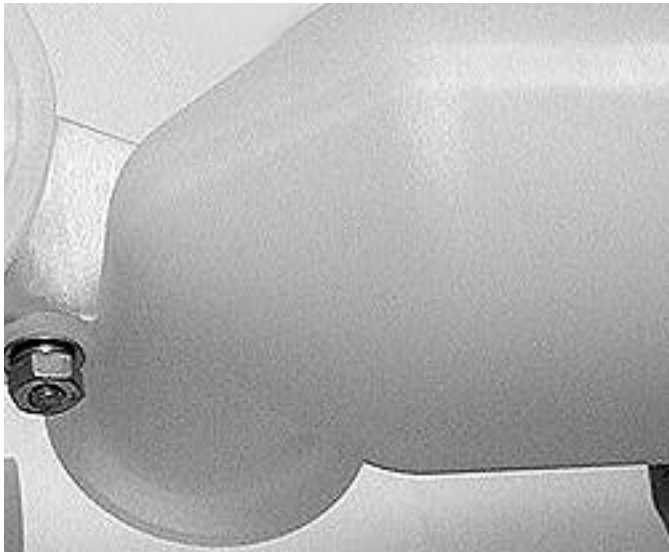

FIGURE 15

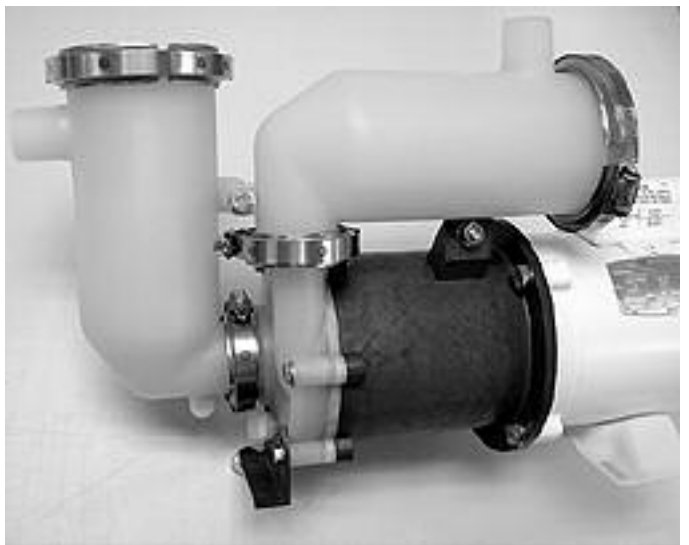

FIGURE 16

END SUCTION MAGNETIC-DRIVE SEAL-LESS PUMP

PARTS LIST
OPERATION INSTRUCTIONS

March 1, 2002



Sethco Division

800 Emlen Way, Telford, PA 18969

Tel: 800-645-0500 • 215-799-2577 • Fax: 215-799-0920

Website: www.sethco.com • e-mail: sales@sethco.com

West Coast Office: 230 N. Crescent Way, Unit I, Anaheim, CA 928014 • Tel: 714-991-0270 • Fax: 714-991-8107

END SUCTION...MAGNETIC-DRIVE...SEAL-LESS

500 SERIES



Models:	PM-510	PM-525	PM-550
	KM-510	KM-525	KM-550

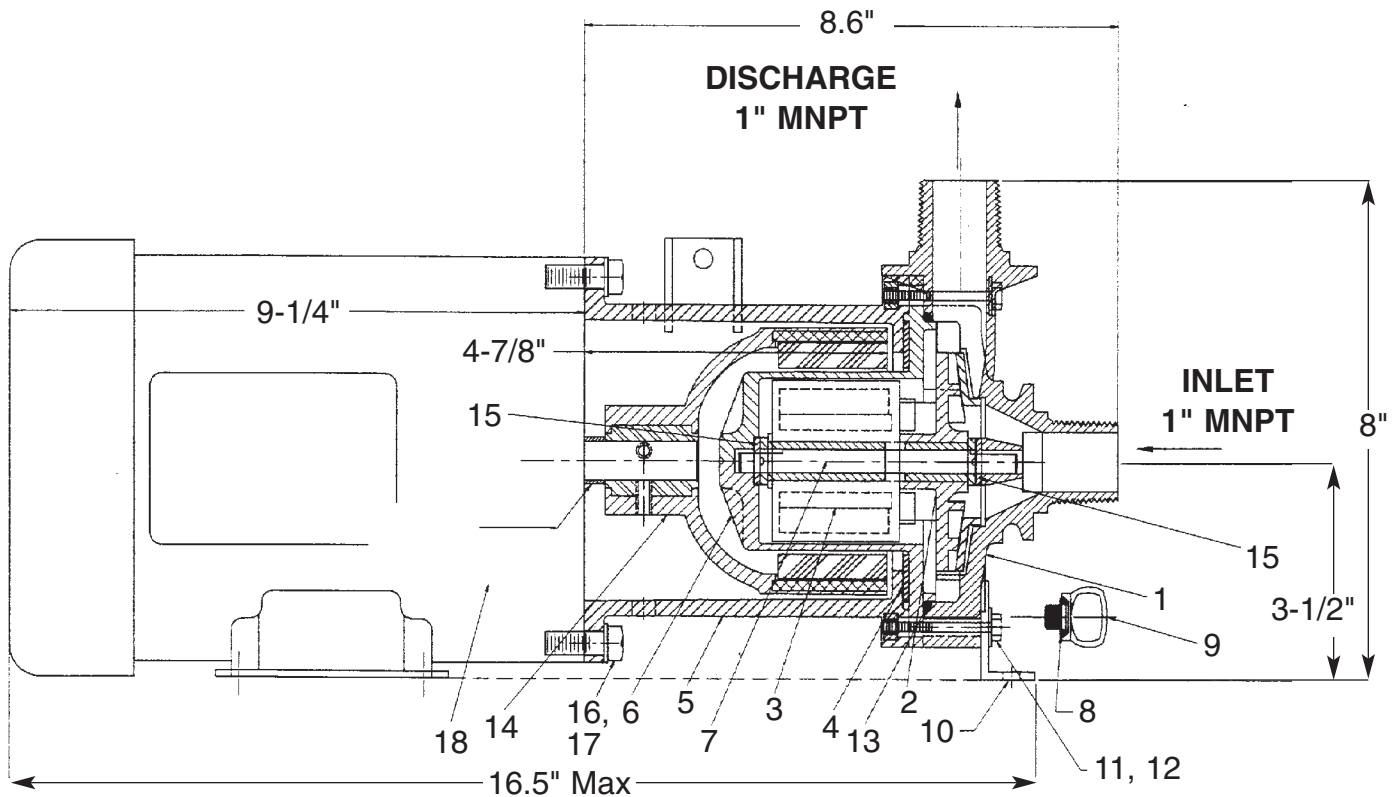

OPERATING INSTRUCTIONS

INSTALLATION

Allow sufficient head room and floor space for proper inspection and maintenance.

PIPING

All piping must be supported independently of the pump. The piping should always line up naturally with the pump. Never draw or force the piping to the suction or discharge of the pump. All installations should be properly designed for changes in ambient operating temperatures. Omission of this could result in severe strain transmitted to the pump. The piping should be as short and direct as possible. Avoid all unnecessary elbows, bends, and fittings, as they increase friction losses in the piping.

SUCTION PIPING

The length of the suction pipe should be as short as possible. **SUCTION PIPING MUST BE AIR TIGHT.**

DISCHARGE PIPING

A valve in the discharge line should be of a design to allow throttling or flow control. Centrifugal pumps should never be throttled on the suction side.

INITIAL START UP

On first start up, and any time motor is reconnected to an electrical outlet, check direction of motor rotation as follows:

1. Fill pump with liquid as directed in priming instructions below.

2. Turn switch "on" and then "off" immediately. Observe rotation. It should be in the direction of the arrow on motor or pump (counterclockwise when looking at pump end of motor).
3. To reverse rotation refer to instructions on motor.

PRIMING AND STARTING

1. **Flooded Suction** - Open all valves in suction and discharge lines. When pump is completely filled with liquid, turn motor on. Occasionally, especially when pumping higher specific gravity liquids, the pump may not start pumping with an open discharge line. To overcome this, simply close the discharge valve after the pump is filled with liquid, then turn on motor. Wait several seconds for pressure to build up, then slowly open discharge valve to desired flow.
2. **Non-Flooded Suction** - Slowly fill the pump and suction line from the inlet side until the liquid flows from the pump discharge port and inlet hose is full. Make sure that no entrapped air remains. Close the discharge valve. Turn on motor. Wait several seconds for pressure to build up. Slowly open discharge valve to desired flow.

Continued on back page

PARTS LIST

SETHCO "PM/KM - 500 SERIES" MAGNETIC-DRIVE, SEAL-LESS END SUCTION PUMP

PM MODELS

KM MODELS

ITEM	DESCRIPTION	QUANTITY	MATERIAL	PART NUMBER	MATERIAL	PART NUMBER
1	CASING	1	POLYPRO ¹	133P400368-576	KYNAR ¹	133P400368-383
2	IMPELLER	1	SEE TABLE BELOW			
3	DRIVEN MAGNET	1	SEE TABLE BELOW			
4	DISK	1	STAINLESS STEEL	250P202089-685	STAINLESS STEEL	250P202089-685
5	ADAPTER	1	NORYL	010P400367-513	NORYL	010P400367-513
6	CUP	1	POLYPRO	180P400373-576	KYNAR	180P400373-383
7	SHAFT	1	CERAMIC	850P102528-150	CERAMIC	850P102528-150
8	O-RING (STANDARD)	1	VITON	590P2111-830	VITON	590P2111-830
8A	O-RING	1	EDPM	590P2111-216	EPDM	590P2111-216
8B	O-RING	1	TEFLON	590P2111-770	TEFLON	590P2111-770
9	DRAIN PLUG	1	POLYPRO	660P2020831-576	KYNAR	660P2020831-383
10	BRACKET	1	NORYL	050P202091-513	NORYL	050P202091-513
11	BOLT	6	STAINLESS STEEL	790P0220106-680	STAINLESS STEEL	790P0220106-680
12	WASHER	10	STAINLESS STEEL	990P0205-680	STAINLESS STEEL	990P0205-680
13	O-RING (STANDARD)	1	VITON	590P2246-830	VITON	590P2246-830
13A	O-RING	1	EPDM	590P2246-216	EPDM	590P2246-216
13B	O-RING	1	TEFLON	590P2246-770	TEFLON	590P2246-770
14	DRIVE MAGNET ASSEMBLY	1	—	561P202085-520	—	561P202085-520
15	THRUST WASHER	2	CERAMIC	990P101934-150	CERAMIC	990P101934-150
16	WASHER	4	STAINLESS STEEL	990P3968706-680	STAINLESS STEEL	990P3968706-680
17	BOLT	4	STAINLESS STEEL	790P03161-680	STAINLESS STEEL	790P03161-680

ITEM	TEFC MOTORS*	QUANTITY	115/208-230V, 50/60 Hz	208-230/308-460V, 50/60 Hz
18A	MOTOR, 1/ 4HP	1	574P00K12113D4E	—
18B	MOTOR, 1/ 3HP	1	574P00L12113D4E	—
18C	MOTOR, 1/ 2HP	1	574P00M32313D40	574P00M35333D40
18D	MOTOR, 3/ 4HP	1	574P00N32313D40	574P00N35333D40
18E	MOTOR, 1HP	1	574P01032313D40	574P01035333D40

* If your motor is "wired" at the factory, change the 1st 3 digits to 575 for low voltage or 576 for high voltage. For other motors, consult factory

NOTE 1: Polypropylene is glass reinforced, Kynar is carbon reinforced.

IMPELLER MAGNET ASSEMBLY BEARING MATERIAL

IMPELLER MATERIAL	MODEL	CARBON	RYTON	SILICONE CARBIDE
POLYPRO	510	430P301450-579	430P301450-578	430P301450-573
	525	430P301451-579	430P301451-578	430P301451-573
	550	430P301452-579	430P301452-578	430P301452-573
KYNAR	510	430P301450-381	430P301450-388	430P301450-386
	525	430P301451-381	430P301451-388	430P301451-386
	550	430P301452-381	430P301452-388	430P301452-386
DRIVEN MAGNET	POLY	562P301431-579	562P301431-578	562P301431-573
	KYNAR	562P301431-381	562P301431-388	562P301431-386

ASSEMBLY / DISASSEMBLY INSTRUCTIONS

You will need the following tools:

1. 7/16" socket
2. 9/16" socket
3. Ratchet
4. 7/16" open-end wrench
5. 1/8" hex allen wrench
6. Torque wrench

DISASSEMBLY

1. Disconnect hoses, fittings and electrical power to the motor.
2. Using 7/16" socket, remove 6 screws and washers (11, 12). Bracket assembly (10) will also be removed at this point. Lift off casing (1), making sure shaft (7) stays with unassembled pump assembly.
3. Remove rear ceramic washer (15) and impeller (2). Inspect both for damage or wear.
4. Remove casing o-ring (13) from cup pilot. Inspect and replace if necessary.
5. Next remove cup assembly (6) with shaft (7), magnet (3), and rear washer (15) in it.
6. Remove parts from cup (6) and inspect.
7. Remove stainless support disk (4) from adapter face.
8. Using 9/16" socket, remove 4 bolts and washers (16, 17) from motor and adapter (5, 18). Remove adapter from motor (18).
9. Use 1/8" allen wrench to loosen 2 set screws in drive magnet (14). Remove drive magnet (14) from motor (18)
10. Inspect all ceramic washers, bearings, and shaft for wear, chips or other signs of wear.
11. Remove drain plug (9) from casing (1) and inspect small o-ring (8). Replace if necessary.

ASSEMBLY

1. Stand motor on fan end so that the shaft faces upward and the motor foot faces you.
2. Install drive magnet (14) onto motor shaft (18). Set distance from end of drive magnet to c-face of motor at 4-7/8". See figure 1.
3. Tighten 2 set screws using 1/8" hex allen wrench once proper distance has been determined.
4. The 4 holes in the adapter should line up with the motor holes when the small adapter "ear" is in the 1 o'clock position looking into the drive magnet (14). See figure 2.
5. Install 4 bolts and washers (16, 17) using 9/16" socket. Torque bolts to 7-9 ft./lbs. max.
6. Check that drive magnet (14) spins freely without hitting adapter (5), turning drive assembly by hand.
7. Install rear ceramic washer (15) onto shaft 'D' (7) with reflective polished face towards longer section of shaft.
8. Insert shaft and washer into cup (6) piloting shaft (7) into cup and seating washer (15) into counter bore in cup (6). See figure 3.
9. Install driven magnet (3) onto cup/shaft subassembly with thrust bearing towards ceramic washer in cup. When installed, 4 standing lugs should be visible from open end of cup. Shaft should extend upward from cup. See figure 4.
10. Install impeller/bearing assembly (2) onto shaft so that 4 standing lugs on impeller locate into 4 slots on driven magnet (3). Turning impeller by hand should now turn driven magnet if properly seated. See figure 5. Place disk (4) onto adapter (5)
11. Lower cup/magnet/impeller assembly into adapter using caution not to catch fingers between cup and adapter. Make sure disk (4) is between cup and adapter and seated in cup (6) pilot. See figure 6.

12. Locate so that cup pilot seats into adapter pilot and all 6 hole sets line up.
13. Install front thrust washer (15) onto shaft (7) with reflective polished surface downward against impeller (2).
14. With motor base (18) at the 6 o'clock position, turn the ceramic shaft (7) so that the flat is at the 9 o'clock position. See figure 7.
15. Install o-ring (13) onto cup (6) pilot. O-ring should be flat on cup. See figure 7.
16. Install drain plug (9) and o-ring (8) into casing (1) until hand tight. Use teflon tape on drain plug.
17. Lower casing (1) onto pump assembly, making sure that the flat in the shaft corresponds with the flat in the casing. Look through casing inlet to ensure proper location.
18. Casing (1) should pilot on o-ring (13) in cup (6). A small gap should be visible from side of assembly (approximately 1/16"). See figure 8.
19. Hand thread all 6 bolts with washers (11, 12) into casing. The bottom 2 should be through bracket (10) also. See figure 9.
20. Tighten 6 bolts using 7/16" socket until all bolts (11) are slightly compressing o-ring. Turn pump horizontal on flat surface, loosen 2 bracket bolts (11), and adjust bracket so that the bottom is flush with base surface. Re-tighten the 2 bolts now. See figure 9.
21. Torque all 6 bolts to 4-5 ft./lbs.
22. You are now ready to prime the pump and wire the motor. Follow the wiring diagram on the motor.

TROUBLESHOOTING

A. Pump will not prime or insufficient liquid delivered:

1. Air leakage in suction piping
2. Suction lift too high or insufficient suction pressure
3. Impeller, casing, suction pipe or strainer plugged with solids
4. Wrong rotation
5. Magnetic couple slipping

B. Not enough pressure:

1. Speed too low.
2. Air or gases in the liquid.
3. Check impeller condition.
4. Mechanical defects (impeller clearance too great: impeller damaged).
5. Wrong rotation.
6. Pressure gauge in the wrong place, (or defective gauge).

C. Pump takes too much power:

1. Speed too high.
2. Head lower than rating; pumping beyond design point.
3. Liquid heavier than specified; check viscosity and specific gravity.
4. Mechanical defects (rotating element rubbing).

D. Pump is noisy:

1. Hydraulic noises—cavitation, insufficient suction pressure.
2. Mechanical defects (rotating parts are binding, loose or broken).

E. Pump leaks:

1. When a leak is detected, stop the pump and check the clamps and fasteners to be sure they are secure. Should the leak continue, secure the pump and inspect all the components for cracks and wear, especially the cup.

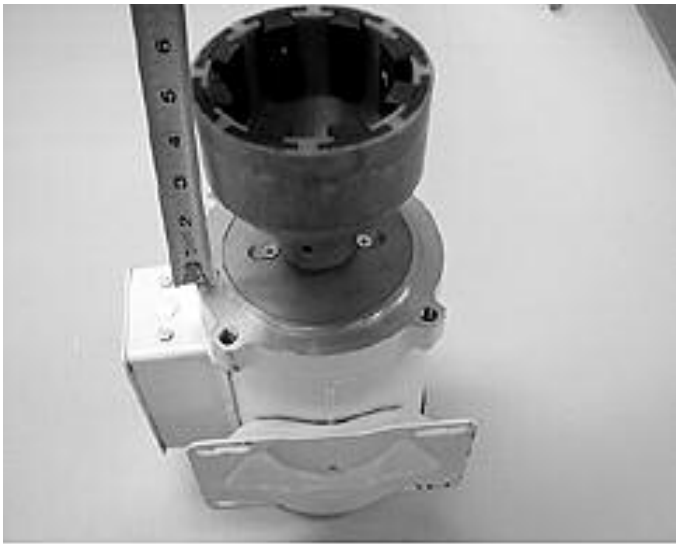

FIGURE 1

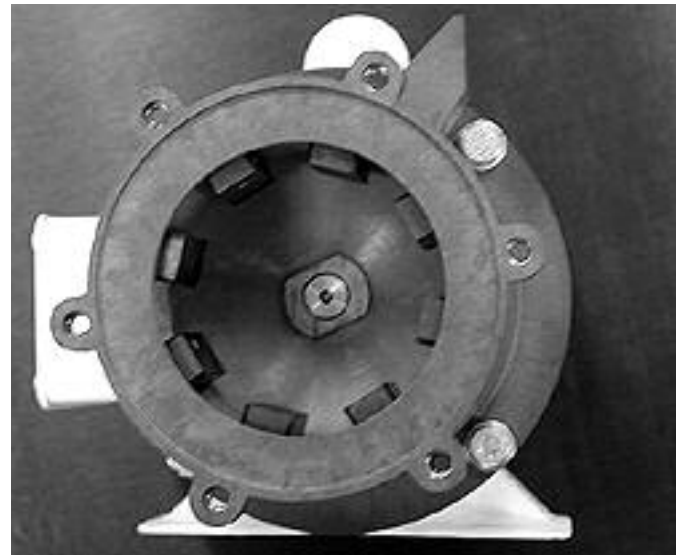

FIGURE 2



FIGURE 3



FIGURE 4



FIGURE 5



FIGURE 6

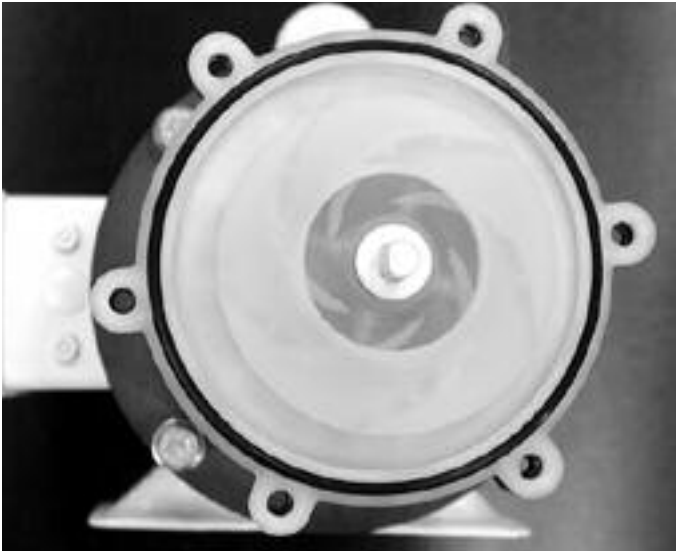

FIGURE 7



FIGURE 8



FIGURE 9